

VIEWMARQ™

LED MESSAGE DISPLAY

Overview

ViewMarq is an Industrial LED Message Display that utilizes the latest LED and communications technologies to help communicate important information. *ViewMarq* can display real-time factory floor data, with messages controlled from a PLC or any other device that uses the supported protocols. Embedded data support allows real-time production data from the controller to be contained within each message. The free configuration software allows you to create pre-formatted message strings that can be loaded into the PLC. This data can then be displayed in real-time messages that help to keep your facility productive and informed.

Features

- UL508, CE, RoHS
- NEMA 4 (Wash Down)
- NEMA 12 (Dust, Oil, Water, and Dirt)



Message Control

The *ViewMarq* message displays utilize both serial and Ethernet communications and can be connected to a PLC or PC or any device capable of serial ASCII master, Modbus RTU, or Modbus TCP communications. Messages can be controlled by any of the following methods:

- ASCII Input Strings through the RS232 or RS485 port
- Modbus RTU Messages through the RS232 or RS485 port
- Modbus TCP Messages through the Ethernet port

Features

- One-, two-, or four-line displays
- Scrolling messages
- Blinking text and messages
- Display embedded PLC string and numeric variables
- Tri-Color LED (Red, Green, Amber)
- Built-in Ethernet port; RS-232, and RS-485 serial ports
- Free, easy-to-use configuration software package
- Low power consumption, high-efficiency switch mode power supply reduces cost of ownership
- Wall mount / cabinet top mount or chain mount - brackets included
- All the configuration parameters are set through software for ease of use. (No DIP switches.)
- Customer configured messages can be sent via an ASCII serial string, Modbus RTU or Modbus TCP protocols
- Serial RS232/485 and Ethernet Modbus TCP communications can be used at the same time



Communicate using:
• ASCII
• Modbus RTU
• Modbus TCP



FREE Configuration Software!

ViewMarq Configuration Software is designed to help you create messages with ease. Simply type your message in the text editor and immediately see the results in the included simulator. Change character colors and sizes or add features such as scrolling and blinking. This software utility gives you multiple functionality, allowing you to:

- Create and preview messages on your PC
- Send messages to the **ViewMarq** LED display
- Configure the **ViewMarq** to communicate with a PLC
- Create ASCII string commands that may be used in the PLC instructions to control the **ViewMarq**. The software generates the required ASCII command string from your message and then allows you to copy and paste the string into your ladder logic program in your PLC.

ViewMarq Configuration Software Part Number: MD-PGMSW

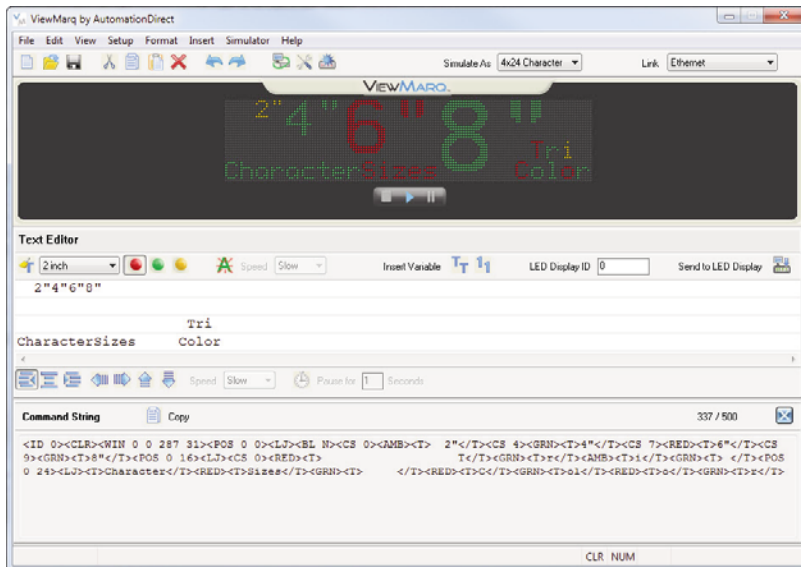

Built-in Message Simulator

- Displays formatted message on your PC as you type.
- Test all of your messages before downloading.
- Saving time saves you money!

Simple Message Creation

- Message creation and editing is made simple and fast with intuitive software. Easy-to-find tools help change the character color, add blinking, and insert embedded variables.

Command String Viewer

- Allows you to copy and paste the command string needed for your PLC ladder code.



Requires Windows XP (Service Pack 3), Vista or Windows 7 (32 and 64-bit) and a serial or Ethernet connection to the *ViewMarq* Display. Purchase cables separately. (An Ethernet cable comes packaged with each *ViewMarq* LED message display.)

Rugged and Reliable

Rugged Industrial Design

The *heavy duty extruded aluminum housing* offers a dependable yet attractive display in even the most demanding industrial environments. *ViewMarq* is one of the few message displays on the market that is NEMA 4 and NEMA 12 rated (indoor only). Access covers with seal-tight cable glands offer reliable, easy installation of power and communication wiring. Adjustable heavy-duty mounting brackets offer secure mounting at various angles or when hung from chains. The unit ships with wall-mount and chain-mount brackets as well an Ethernet cable to help you get started. The NEMA 4 and NEMA 12 cable gland fittings for communications and power wiring are also included in the package.

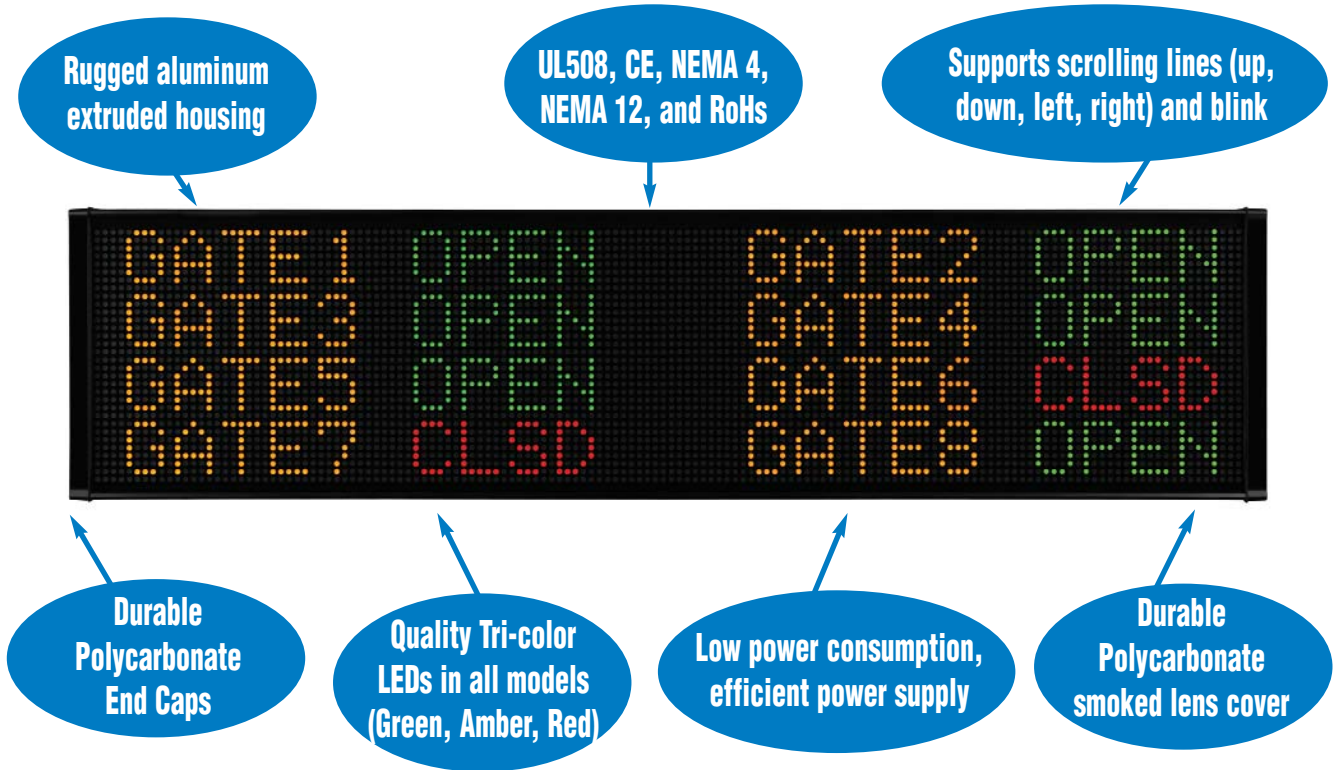

Heavy duty mounting brackets (included)

Wall or Ceiling Mount

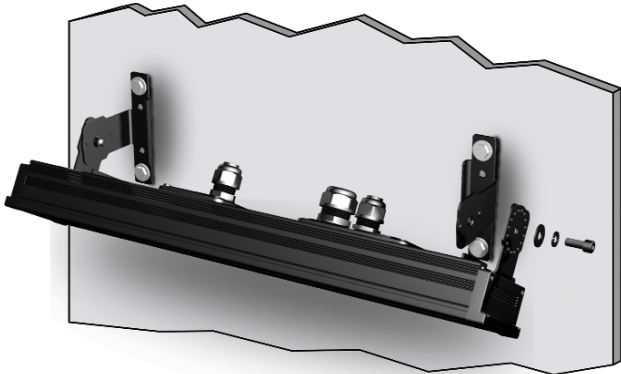

Chain Mount



Choosing the Right Model

One-Line Displays

- 1-1/4", 2" characters
- Models with 12 or 24 characters per line
- Approximate viewing distance up to 100 ft

MD4-0112T



MD4-0124T



Two-Line Displays

- 1-1/4", 2", 4" characters
- Models with 12 or 24 characters per line
- Approximate viewing distance up to 200 ft

MD4-0212T



MD4-0224T



Four-Line Displays

- 1-1/4", 2", 4", 6", 8" characters
- Models with 12 or 24 characters per line
- Approximate viewing distance up to 400 ft

MD4-0412T



MD4-0424T



Here are the recommended viewing distances based on the character size that can be used:

Character Size	Minimum Recommended Viewing Distance	Maximum Recommended Viewing Distance	Displays with these character sizes (Part Numbers)
1.25 in	6 ft	60 ft	MD4-0112T MD4-0124T MD4-0212T MD4-0224T MD4-0412T MD4-0424T
2 in	10 ft	100 ft	MD4-0112T MD4-0124T MD4-0212T MD4-0224T MD4-0412T MD4-0424T
4 in	20 ft	200 ft	MD4-0212T MD4-0224T MD4-0412T MD4-0424T
6 in	20 ft	300 ft	MD4-0412T MD4-0424T
8 in	20 ft	400 ft	MD4-0412T MD4-0424T

